

HULTDINS TM SuperSaw

SuperSaw 650S

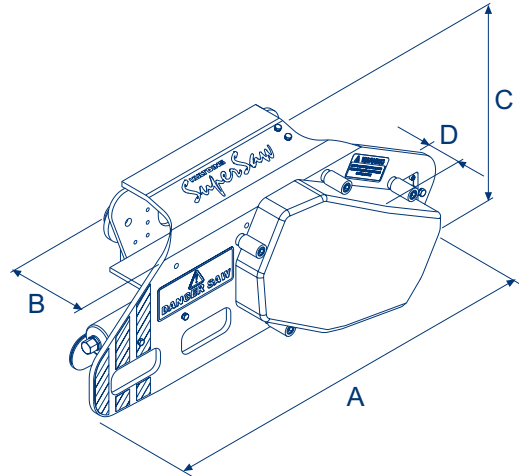

- Features:**
- Automatic chain tension.
 - Automatic saw bar return.
 - Built in proportional lubrication system.
 - Built in bar feed cylinder.
 - Simple carrier installation.

Technical Data

SuperSaw

Saw motor displacement
Weight

cc (cm³)
lb (kg)

650S

40 (40)
495 (225)

Length "A"
Width "B"
Height "C"
Width "D"

inches (mm)
inches (mm)
inches (mm)
inches (mm)

48.63 (1235)
16.38 (416)
20.00 (508)
5.75 (146)

Hydraulic pressures and flows

Min. hydraulic pressure, saw motor
Rec. hydraulic pressure, saw motor
Max. hydraulic pressure, saw motor
Min. flow, saw motor
Rec. flow, saw motor
Max. flow, saw motor

psi (MPa)
psi (MPa)
psi (MPa)
gpm (l/min)
gpm (l/min)
gpm (l/min)

2900 (20)
3150 (22)
3900 (27)
53 (200)
55 (207)
58 (218)

Chain tension
Chain lubrication
Saw bar standard
Saw bar optional
Saw chain
Max. saw chain speed
Max. power input to saw chain

Automatic
Proportional
34" (87 cm)
40" (100 cm)
3/4"-11H
see recommendation from each saw chain manufacturer
see recommendation from each saw chain manufacturer

0102-7000608-CAN



Hultdins Inc.
P.O.Box 1205, 22 Morton Ave. East
Brantford, Ontario, Canada N3T 5T3
Tel (519) 754-0044, Fax (519) 754-1569
E-mail: info@hultdins.com
www.hultdins.com