

HULTDINS SuperCut

SuperCut Standard

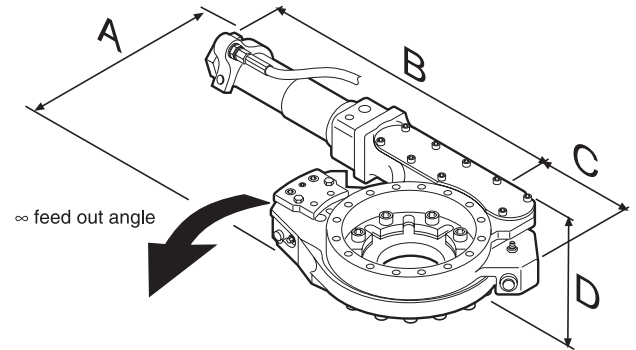
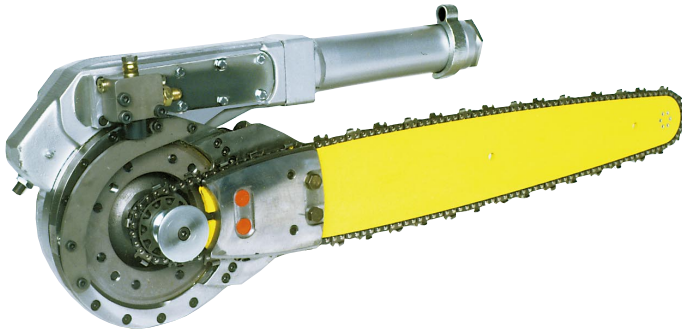

Features:

- Automatic chain tensioning.
- Built in feed cylinder.
- Fast saw bar and chain replacement
- Integral saw motor mount.
- Proportional chain lubrication
- Simple installation.

Technical Data:

		F11-10		F11-19	
Saw Motor Displacement		0.61 in ³	(10 cm ³)	1.16 in ³	(19 cm ³)
Hydraulic Pressure (min.)		2,300 psi	(16 MPa)	2,300 psi	(16 MPa)
Recommended Pressure		3,600 psi	(25 MPa)	3,600 psi	(25 MPa)
Hydraulic Pressure (max.)		4,500 psi	(31 MPa)	4,500 psi	(31 MPa)
Hydraulic Flow (min.)		21 GPM	(80 l/min)	35 GPM	(135 l/min)
Recommended Flow		29 GPM	(110 l/min)	48 GPM	(180 l/min)
Hydraulic Flow (max.)		35 GPM	(135 l/min)	58 GPM	(220 l/min)
Saw Bar and Chain		0.404		0.404	
Chain Tension		Automatic		Automatic	
Chain Lubrication		Proportional		Proportional	
Dimensions:	"A"	11.3 in.	(286.5 mm)	11.3 in.	(286.5 mm)
	"B"	18.62 in.	(473 mm)	18.62 in.	(473 mm)
	"C"	5.31 in.	(135 mm)	5.31 in.	(135 mm)
	"D"	4.72 in.	(120 mm)	4.72 in.	(120 mm)
	"E"	11.3 in.	(286.5 mm)	11.3 in.	(286.5 mm)
Weight (with saw motor)		73 lb	(33 kg)	82 lb	(37 kg)

Maximum Saw Chain Speed: See recommendation from each saw chain manufacturer.

Maximum Power Input to Saw Chain: See recommendation from each saw chain manufacturer.

P/N 9909031



Hultdins Inc.
P.O. Box 1205, 22 Morton Ave. East
Brantford, Ontario, Canada N3T 5T3
Tel: (519) 754-0044, Fax: (519) 754-1569
E-mail: info@hultdins.com
www.hultdins.com

Hultdin System AB
Skolgatan 12, 930 70 Malå, Sweden.
Tel: +46 953 10720, Fax: +46 953 21426
E-mail: sales@hultdins.se
www.hultdins.se